

Washer extractor

W585S

Features and benefits

- **Compass Pro® microprocessor offers:**
 - Large display and one control knob for easy program selection
 - Language selection
 - Quick selection and option buttons for the most frequently used wash programs and options
 - Wash program packages optimized on Economy, Performance and Time. (Available on general programs)
- **AS – Automatic Savings:**
 - The machine weighs the linen and adjusts the amount of water and energy according to the load. This leads to considerable savings in case the machine is not fully loaded. (Available on general programs)
- Extremely low water and energy consumption – see table below
- Four compartment detergent box for manual dosing of powder or liquid detergent
- High extraction force for efficient dewatering
- Door with gasket and strong hinges built for heavy duty operation
- Stainless and galvanized steel in all vital parts for high degree of rust protection
- SuperBalance guarantees the correct extraction force



Images shown are a representation of the product only and variations may occur.

Main options

- Automatic liquid detergent supply (optional I/O board)
- Stainless steel front panel
- Connection to booking- /payment- system or coin meter
- Drain pump

| Main specifications | | | | W585S | | | |
|---|--------------------|-------|--------------|-----------------|---------------------|-----------------|---------------------|
| Max. capacity | filling factor 1:9 | kg/lb | | 9/20 | | | |
| Drum, | volume | litre | | 85 | | | |
| | diameter | ø mm | | 520 | | | |
| Extraction | | rpm | | 830 | | | |
| G-factor | | | | 200 | | | |
| Standard heating alternatives | electricity | kW | | 5.4 / 7.5 | | | |
| Low energy heating alternatives | electricity | kW | | 2.0 / 3.0 | | | |
| | steam | | | X | | | |
| | non-heated | | | X | | | |
| Consumption data "Normal 60°C" | | | | EL | | Steam*** | |
| Economy* | | | | Full load, 9 kg | Half load**, 4.5 kg | Full load, 9 kg | Half load**, 4.5 kg |
| Total time | | min | 45 | 43 | 45 | 43 | |
| Water consumption (cold+hot) | | litre | 56+16 | 39+10 | 72+0 | 49+0 | |
| Energy consumption (motor/heating/hot water) | | kWh | 0.1/0.45/1.0 | 0.1/0.3/0.65 | 0.1/- | 0.1/- | |
| Steam consumption | | kg | - | - | 2.2 | 1.1 | |
| Residual moisture | | % | 58 | 66 | 58 | 66 | |
| * Water temperature 15°C cold water and 65°C hot water. | | | | | | | |
| ** Programs with AS. | | | | | | | |
| *** Depending on steam pressure. | | | | | | | |

| Electrical connections* | | | | | |
|-------------------------|---------------|-------|------------------|----------------|--------------------|
| Heating alternative | Main voltage | | Heating power kW | Total power kW | Recommended fuse A |
| | | Hz | | | |
| Electric heated | 220-240V 1 - | 50/60 | 5.4/7.5 | 5.7/7.8 | 25/35 |
| | 220-240V 1 - | 50/60 | 2.0/3.0 | 2.3/3.3 | 16 |
| | 220-240V 3 - | 50/60 | 5.4/7.5 | 5.7/7.8 | 16/25 |
| | 380-415V 3N - | 50/60 | 5.4/7.5 | 5.7/7.8 | 10/16 |
| | 440V 3 - | 60 | 7.5 | 7.8 | 16 |
| | 480V 3 - | 60 | 7.5 | 7.8 | 16 |
| Steam or Non heated | 220-480V 1 - | 50/60 | - | 0.4 | 10 |

| Water and steam connection | | W585S |
|-----------------------------------|---------------------------|-----------|
| Water valves | DN | 20 |
| Water pressure | kPa | 200-600 |
| Capacity at 300 kPa | l/min | 20 |
| Drain valve | ∅ mm | 75 |
| Draining capacity | l/min | 170 |
| Steam valve | DN | 15 |
| Steam pressure | kPa | 300-600 |
| Liquid detergent supplies | | 5 |
| Floor requirements | | |
| Frequency of the dynamic force | Hz | 13.8 |
| Floor load at max extraction | kN | 1.7 ± 2.6 |
| Sound levels | | |
| Sound power level (IEC 60704-2-4) | | |
| wash | dB(A) | 64 |
| extraction | dB(A) | 75 |
| Heat emission | | |
| % of installed power, max | | 5 |
| Shipping data** | | |
| Weight | net, kg | 114 |
| Shipping volume | m ³ | 0.79 |
| Accessories | | |
| Steel base | | x |
| Hose kits for water or steam | | x |
| Fluff collector | | x |
| Dimensions in mm | | |
| A Width | | 660 |
| B Depth | | 722 |
| C Height | | 1133 |
| D | | 410 |
| E | | 1153 |
| F | | 836 |
| G | | 80 |
| H | | 1035 |
| I | | 217 |
| J | | 124 |
| K | | 1015 |
| L | | 915 |
| M | | 278 |
| N | | 103 |
| O | | 199 |
| 1 Operating panel | 7 Drain | |
| 2 Door opening ∅ 310 mm | 8 Liquid detergent supply | |
| 3 Detergent box | 9 Electrical connection | |
| 4 Cold water | 10 Steam connection | |
| 5 Hot water | | |
| 6 Re-used water | | |

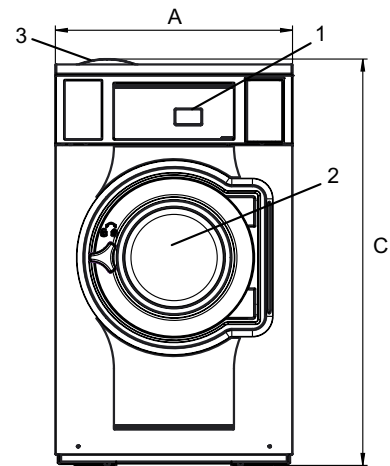

Front

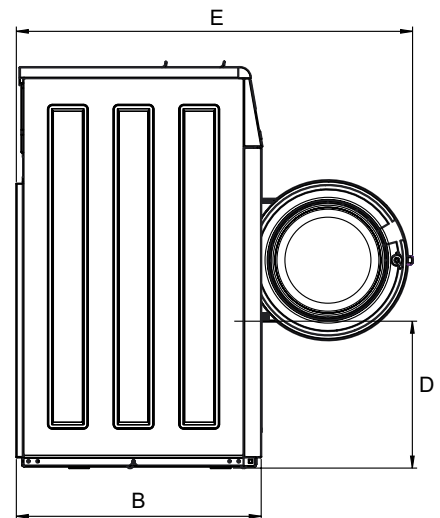

Side view

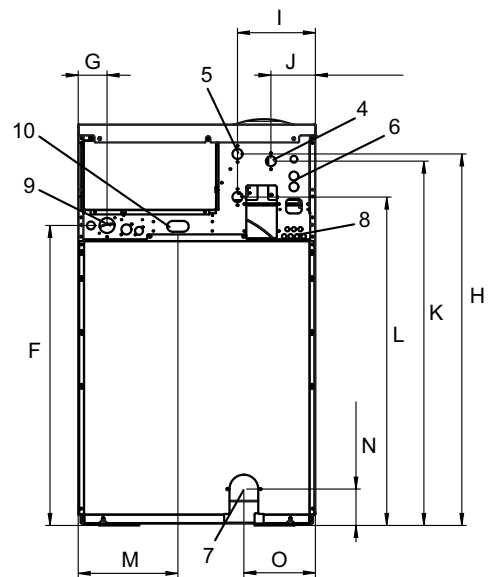

Rear

Front and side panels in light grey and blue (RAL 260 70 05, 250 60 30)

* Other voltages available, see installation manual

** Average data. Crated weight/shipping volume depends on configuration. Please contact logistics for exact measures.